

2.2.2. Rear side of machine head megatap II / microtap II

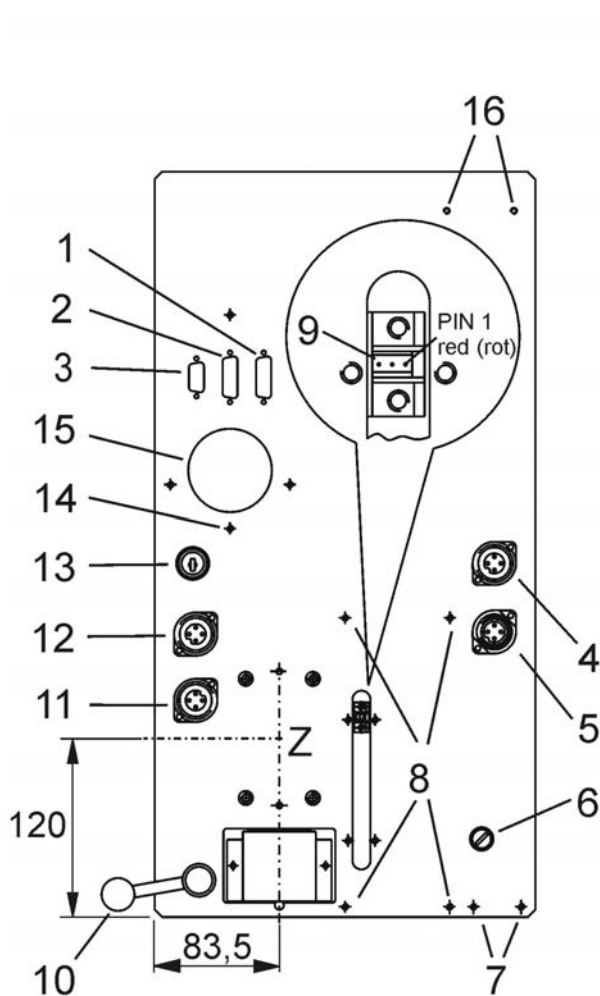

Fig. 2-4 Rear side of machine head megatap II

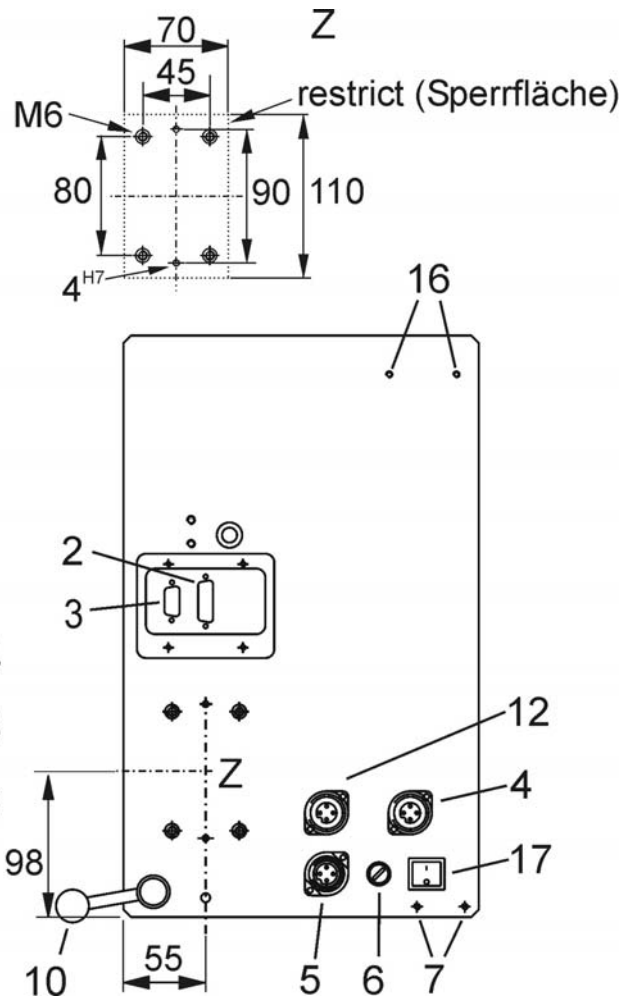

Fig. 2-5 Rear side of machine head microtap II

- | | |
|--|--|
| 1 Connection: ZAP | 9 Receptacle: press sensor ZAP
PIN1 = red |
| 2 Receptacle: I/O user interface (SPS)
(I/O) | 10 Setting lever for retracting force
(counter balance) |
| 3 Receptacle: V24 (RS 232D) serial
interface | 11 Receptacle: Operating lever |
| 4 Receptacle: lubrication unit (SME and
SPE) | 12 Receptacle: Foot switch ZAP |
| 5 Receptacle: Main connection (230VAC
/ 50Hz) | 13 Key switch (option) |
| 6 Fuse: megatapII 16A / T
microtapII 3,15A / TT | 14 Zugentlastung für Leitungen |
| 7 SME connection (SME & SPE) | 15 Air intake hole for cooling fan |
| 8 ZAP connection (ZAP) | 16 signaltap connection |
| | 17 Mainswitch |